

Linea Osmosi Inversa+GAS

# Dolomiti-Gas

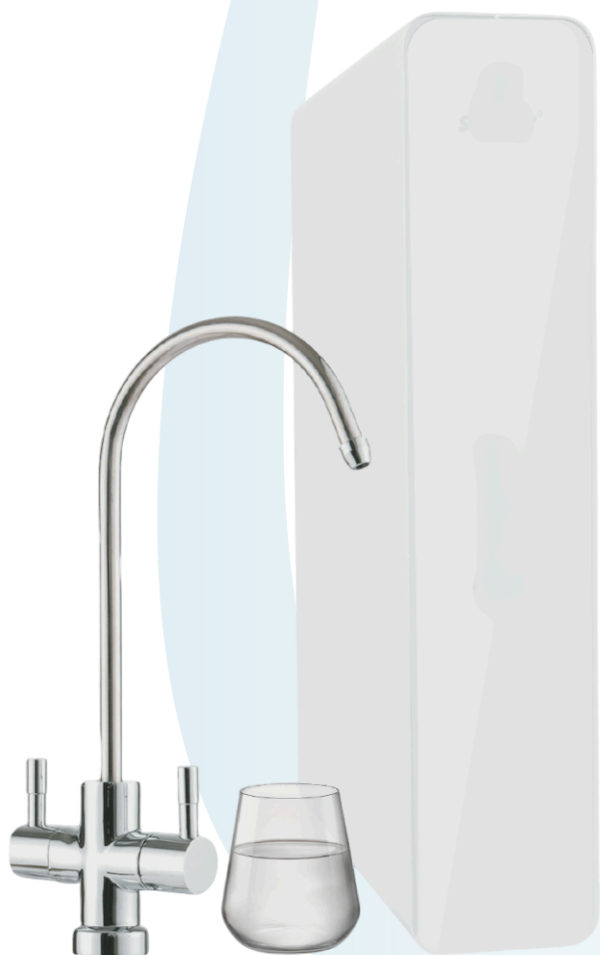

Life System



*100 litri/h*

*...acqua pura a  
km zero!*

- *Sistema diretto*
- *Acqua liscia o gassata*
- *Regola la salinità*
- *Centralina elettronica di controllo*
- *Made in Italy*

Life System  
Wellness Technology



Linea Osmosi Inversa+GAS

# Dolomiti-Gas



Life System

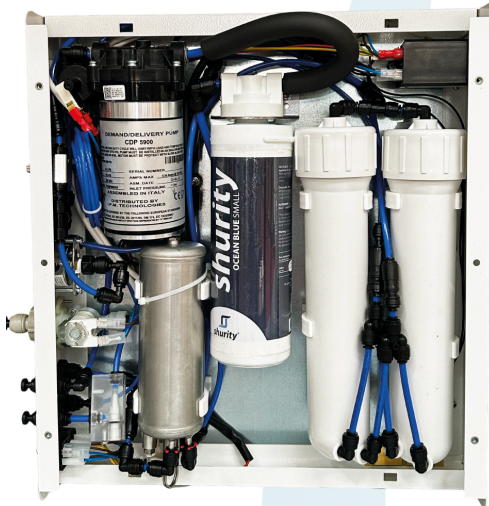

- **SISTEMA ACQUA STOP**  
*Previene perdite d'acqua bloccando il sistema.*
- **CENTRALINA ELETTRONICA DI CONTROLLO**  
*Controllo di ogni fase di funzionamento e soprattutto controllo della qualità dell'acqua erogata.*

## CARATTERISTICHE:

- Erogazione di acqua osmotizzata a temperatura ambiente
- Produzione nominale: 100/120 l/h
- Pressostato a bassa pressione
- Pompa booster V220 150 Psi 120 l/h
- Carbonatore: 600 ml
- Membrane per osmosi: 2 x 200 GPD Valvola di regolazione pressione
- Manometro pressione lavoro
- Centralina con sistema di controllo e Sistema anti-allagamento
- Conducibilità max acqua ingresso 2000 TDS
- Pressione H<sub>2</sub>O ingresso: 1.8 – 4 bar, non-shock. **\*\*La pressione deve restare stabile.\*\***
- Pressione di esercizio: 7 – 8 bar
- Alimentazione: 230V – 50 Hz
- Potenza assorbita max: 180 W
- Peso: 12 Kg.
- Dimensioni: 45,5(h) x 42(p) x 9,5(l) cm

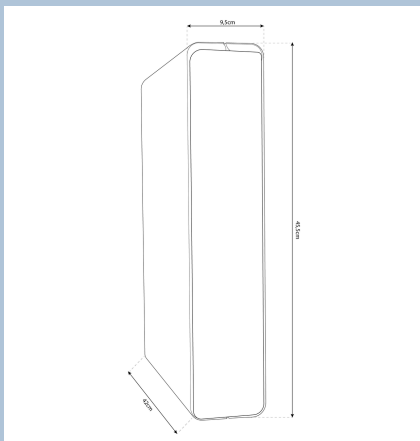

MADE IN ITALY



LIFE SYSTEM srls - via Umberto Maddalena, 11/A 22063 Cantù (CO)  
contatti: [info@lifesystem.it](mailto:info@lifesystem.it) - web: [www.lifesystem.it](http://www.lifesystem.it)  +39 353 481 6798